



71470C - EMERGENCY BATTERY BACKUP

75-120W 120-277V



FEATURES:

- For use with classic wallpacks
- 75-120W
- 120-277V
- Constant Power Output
- Open Circuit Protection
- Short Circuit Protection
- 5 Year Warranty
- cULus Listed

Chemistry	Compliant	Pack Capacity	Max Load for 90min	Battery voltage	Recharge time
LiFePO4	RoHS	2200mAH	12W	14.8V	24Hrs

MECHANICAL:

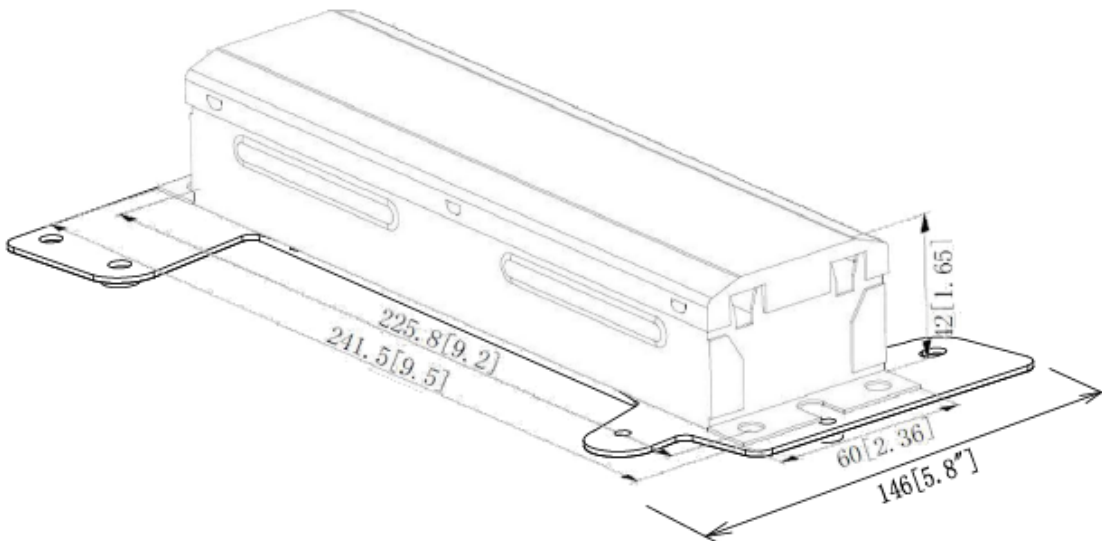



71470C - EMERGENCY BATTERY BACKUP

ELECTRICAL DATA

Input Voltage: 120-277 VAC
Frequency: 50/60 Hz
Power Factor: > 0.6 @ full load
Input Current Max: 100mA
Standby Power: < 5W
White/Black lead: Switch

Output Voltage: 50-200V
Output Current: 60-240mA
Output Power: 12W max
Output Short Protection: Yes
Output Open Protection: Yes
Output Power Setting: Fixed

Operating Temperature: 0 C - 50 C
Storage Temperature: -20 C - 80 C
Operating Humidity: 20 - 85 RH
Storage Humidity: 10 - 85 RH

Over Current Protection: Fuse
Application: For dry and damp location
Safety Standards: UL 924
EMI/EMC Standards: FCC Part15 Class A

WIRING DIAGRAM (TYP)

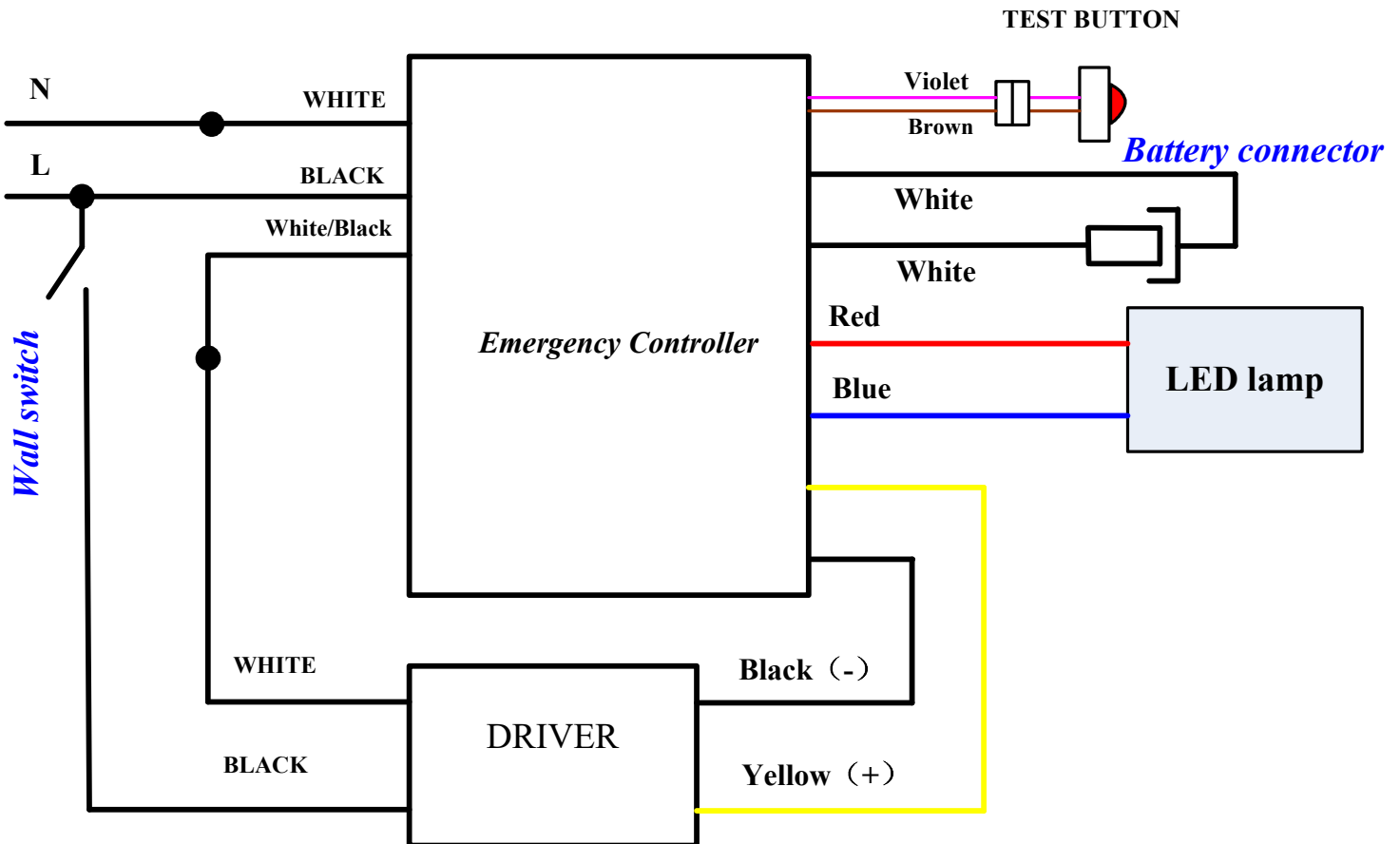



71470C - EMERGENCY BATTERY BACKUP

CAUTION

PLEASE READ CAREFULLY AND FOLLOW ALL INSTRUCTIONS FOR YOUR OWN SAFETY

Important : An un-switched AC power source of 120V AC to 277V AC is required.

This device is designed for use in fixtures listed for dry and damp locations.

CAUTION: Make sure all electrical connections conform to the National Electrical Code and all applicable local regulations.

CAUTION: Do not let power supply cords touch hot surfaces.

CAUTION: Do not mount near gas or electric heaters.

CAUTION: Battery is rechargeable NiCd or LiFePO4 type and must be recycled or disposed of properly .

Do not use this emergency driver with accessory equipment other than recommended by manufacturer.

Do not use this emergency driver for other than intended use.

Failure to follow this may cause an unsafe condition. Servicing should only be performed by qualified service personnel.

Equipment should be mounted in locations and at heights where it will not readily be subjected to tampering by unauthorized personnel.