



**Catalog Number** See Table  
**UPC Number**  
**Description** Cable Tie - UV Black  
 250 Lb Tensile Strength



**Features**

- Durable Nylon 6/6 Material
- Low Profile Locking Head
- Bent Tip for ease of insertion into locking head

**General**

**Material:** Nylon 6/6  
**Flammability:** UL94V-2

**Dimension Information**

**Length:** See Table  
**Width:** See Table  
**Bundle Dia:** See Table

**Specifications**

**Temperature Rating** Negative 40 to 185<sup>0</sup> F  
**Voltage Rating** 600  
**Flammability Rating** UL 94V-2  
**Tensile Strength:** 250 Lbs  
**UV Resistance:** UV Resistant Carbonaten A additive

**Packaging**

**Bag Qty** 100

**Certifications**

**UL** Yes  
**CSA** Yes  
**ROHS** Yes

Cat No.	Tensil Strength (Lbs.)	Length (Inches)	Width (Inches)	Max Bundle Dia (Inches)	Bag Qty	Master Bag Qty	
20294	250	21 5/8	0.5	6.54	100	100	
20296	250	28 1/2	0.5	8.86	100	100	
20298	250	40 1/2	0.5	12.48	100	100	

[www.morrisproducts.com](http://www.morrisproducts.com)

Morris Products 53 Carey Road, Queensbury, NY 12804



**DNV**

E-4988

**Lloyd's Register**

06/10038

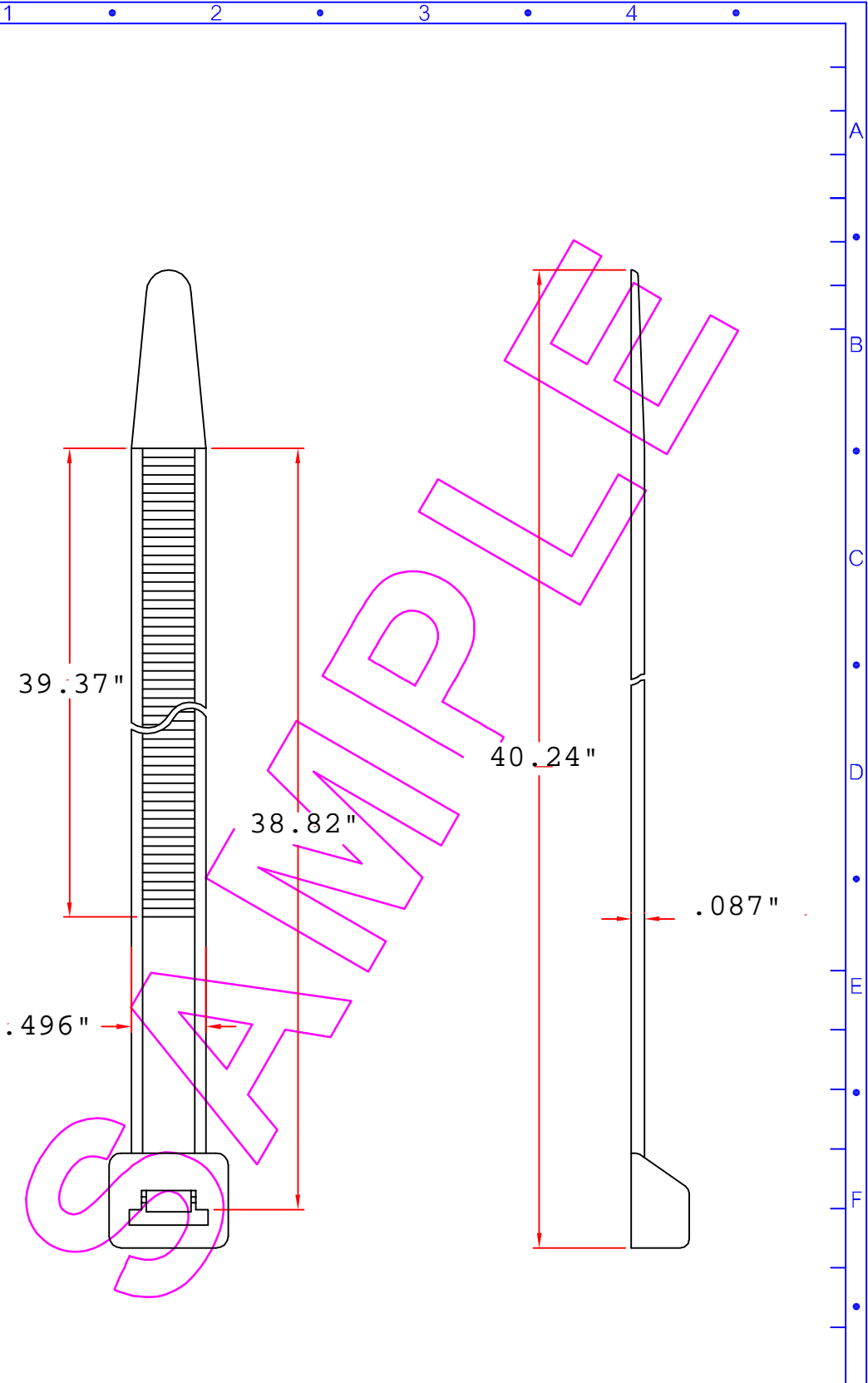

MATERIAL: UL 94V-2

ITEM NO. 20298

NYLON 66

SCALE

UV Black

NAME EXTRA HEAVY DUTY TIE

Morris Products  
Queensbury NY

DATE 03-23-2007

REVISIONS K001

R.NO.