



Catalog Number See Table
UPC Number
Description Aluminum Parallel Groove Clamp
 #10 - 400 MCM



- Features**
- Manufactured from Thermally Treated Extruded Aluminum Alloy
 - Steel Galvanized Set Screws
 - Feed /Tap Configuration for Low Voltage Power Distribution

General

Material Extruded Aluminum Alloy
Screw Type Galvanized Steel
Screw Thread
Wire Range #10 awg - 400 MCM

Dimension Information
 See Table

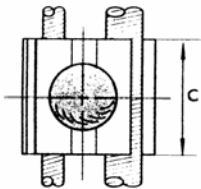

Specifications

Temperature Rating
Voltage Rating 600
Flammability Rating
Amp Rating

Packaging
Box Qty See Table

Certifications

UL N/A
 cUL N/A
 RoHS N/A

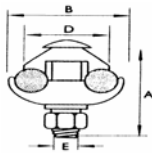

Cat No.	Figure	Main			Tap			Inches					Box Qty
		CU-AL	ACSR	Wire Diameter	Cu-AL	ACSR	Wire Diameter	A	B	C	D	E	
96012	1	10-1/0	6-1/0	.102-.398	10-2	6-2	.102-.325	1.5	1.5	1.24	1.14	0.394	50
96016	1	10-2/0	6-1/0	.098-.417	10-2/0	6-1/0	.098-.417	1.5	1.5	1.24	1.14	0.394	50
96020	1	1/0-4/0	1/0-4/0	.373-.563	8-1/0	6-1/0	.128-.398	1.97	1.89	1.46	1.5	0.394	50
96024	1	1/0-397.5	1/0-336.4	.373-.720	6/2/0	6-1/0	.162-.417	2.36	2.24	1.67	1.67	0.394	50
96028	1	397.5-400	397.5	.728-.740	397.5-400	397.5	.728-.740	2.36	2.56	1.57	1.97	0.472	50

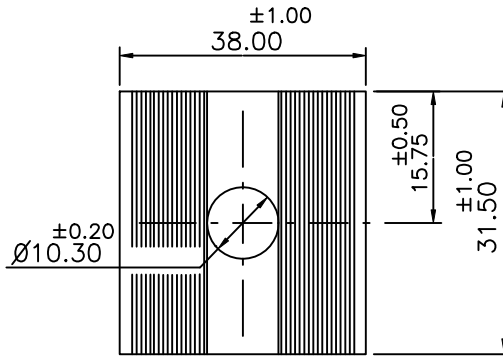
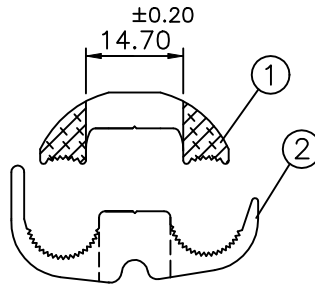
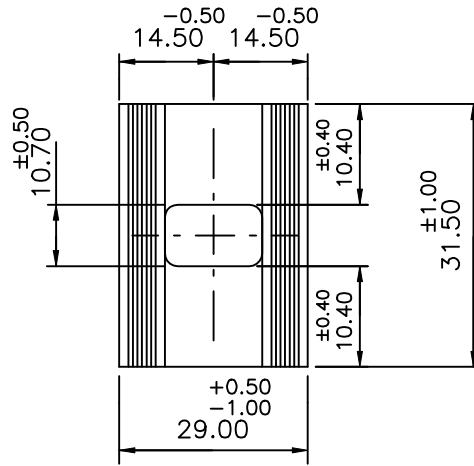

MARKING

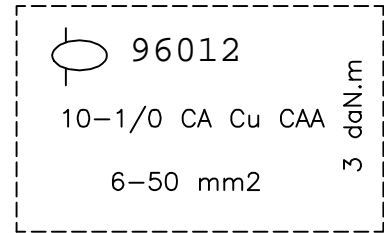

TORQUE: 3 daN.m

:Conectors are Prefilled with antioxide compound and packed in individual plastic bags.

DIMENSIONS IN mm

REF: NORMAL

05	Pressure Washer 3/8"	01	STEEL SAE 1060/1070 Hot Galvanized		
04	Hex Nut 3/8" BSW	01	STEEL SAE 1010/1020 Hot Galvanized		
03	Round Head Bolt 3/8"BSW x 1.1/2"	01	STEEL SAE 1010/1020 Hot Galvanized		
02	Upper Body	01	Aluminum alloy		
01	Lower Body	01	Aluminum alloy		
ITEM	DENOMINATION	QTY	MATERIAL	P.L.	P.B.

09		03/08/11	
08		06/11/98	
07		10/08/95	
06		09/03/95	
05		25/05/94	
04		06/04/92	
03		15/01/92	
02		27/06/91	
01		12/02/90	
No		Date	

Morris Products Inc.
53 Carey Rd.
Queensbury, NY 12804

			Date	No
			09/03/95	96012
Revisions	Appv'l		09/03/95	01 DE: 01