



Catalog Number 91692
UPC Number 60198691692
Description Copper Pipe Ground Clamp 1 1/4" - 2"
with armored/unarmored cable adaptor
Adaptor Serrations



Features

- Manufactured from High Strength High Conductivity Cast Copper Alloy
- Steel Zinc Plated Set Screws
- Water Pipe, Ground Rod, Copper Tubing applications
- Internal Serrations for improved contact integrity
- Serrated Apaptor for armored or unarmored cable ground

General

Pipe Size: 1 1/4" - 2"
Material: High Conductivity Cast Copper
Screw Type: Zinc coated steel
Screw Thread:
Wire Range: #8 awg - 4/0

Dimension Information

Width: 3.54"
Height: 1.40"

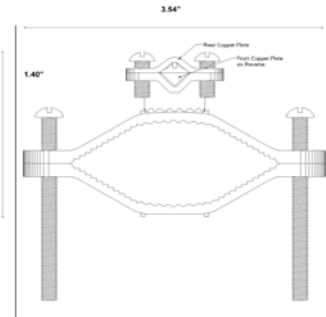

Specifications

Temperature Rating
Voltage Rating 600
Flammability Rating
Amp Rating

Packaging

Box Qty 10

Certifications

UL Yes
cUL Yes
RoHS Yes

www.morrisproducts.com

Morris Products 53 Carey Road, Queensbury, NY 12804

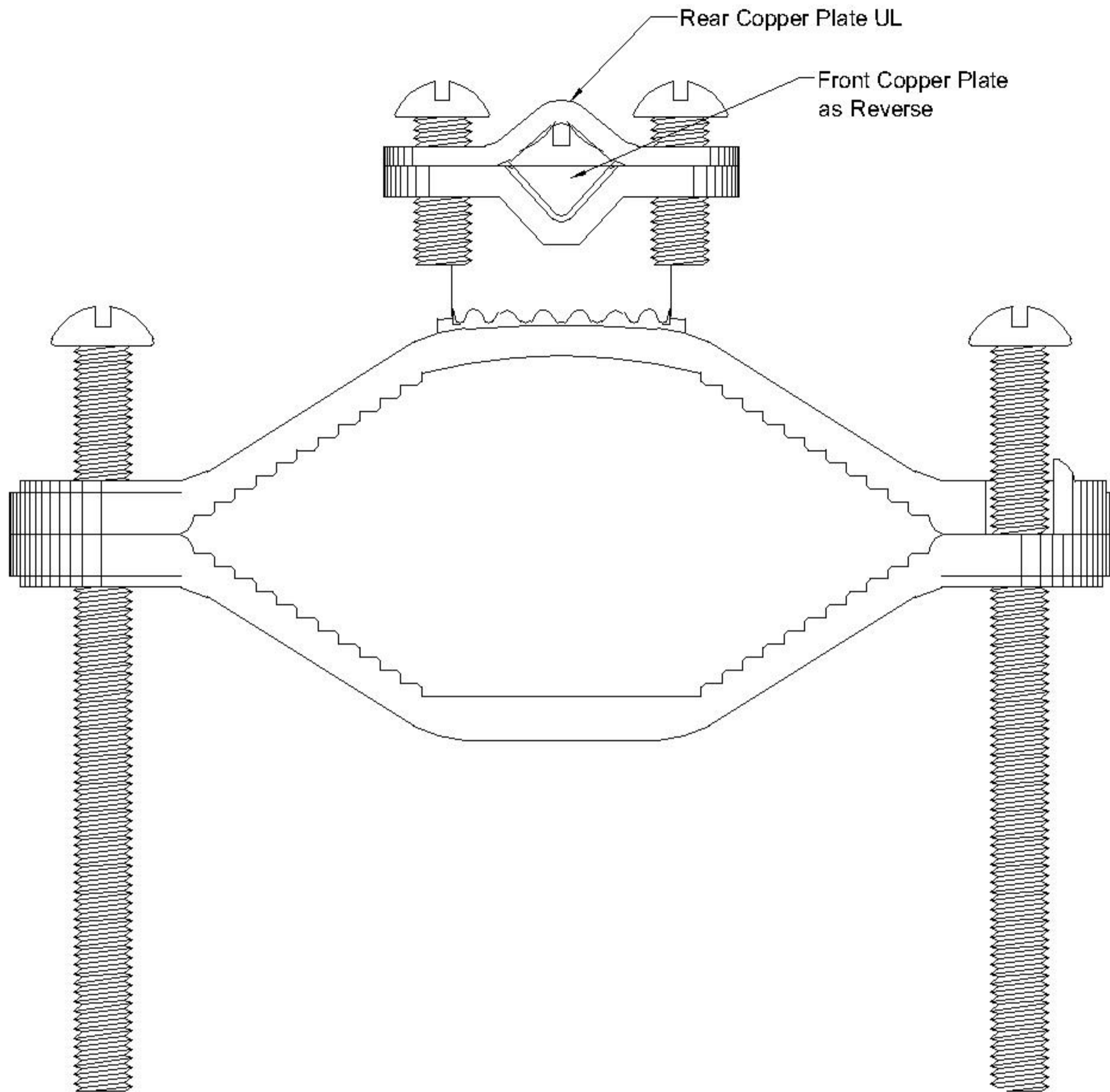

Morris Products Inc.

53 Carey Rd. Queensbury NY 12804

	NAME	DATE
DRAWN	N.D.Parmar	18/01/2004
CHECKED	V.G.Patel	18/01/2004
APPROVED	V.G.Patel	18/01/2004
MATERIAL-	Copper Alloy with copper above 80 %	
TOLERANCE-	±0.50	

SCALE- N.T.S.

TITEL- **Ground Clamp**

TREATMENT- **Shot Blasting**

All Dimensions are in mm

Drawing No.- 91692

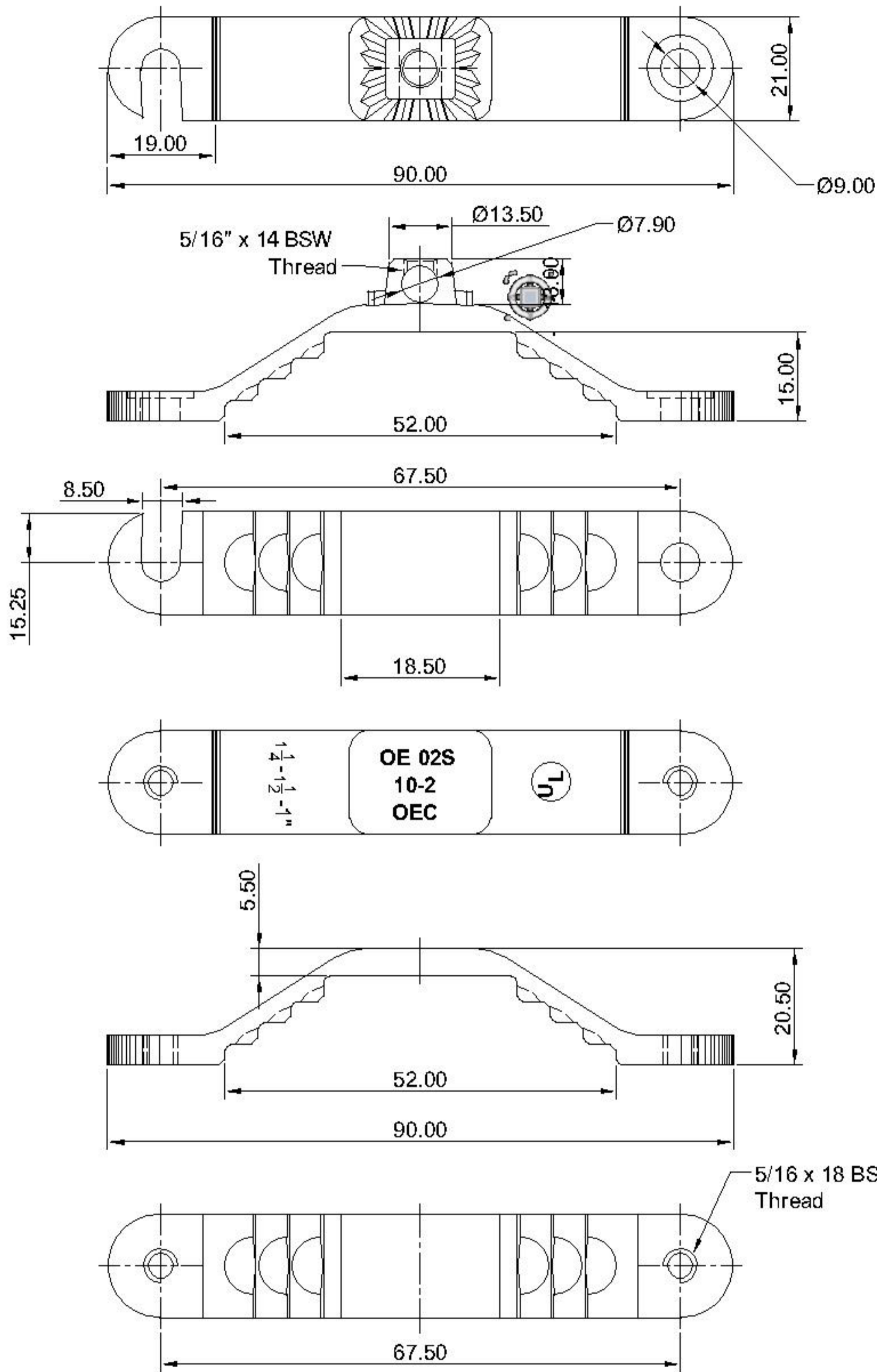

Morris Products Inc.

53 Carey Rd. Queensbury NY 12804

	NAME	DATE
DRAWN	N.D.Parmar	18/01/2004
CHECKED	V.G.Patel	18/01/2004
APPROVED	V.G.Patel	18/01/2004
MATERIAL-	Copper Alloy with copper above 80 %	
TOLERANCE-	±0.50	

SCALE- N.T.S.

TITEL- **Ground Clamp**

TREATMENT- **Shot Blasting**

All Dimensions are in mm

Drawing No.- 91692-B

Screws for Pipe Clamp

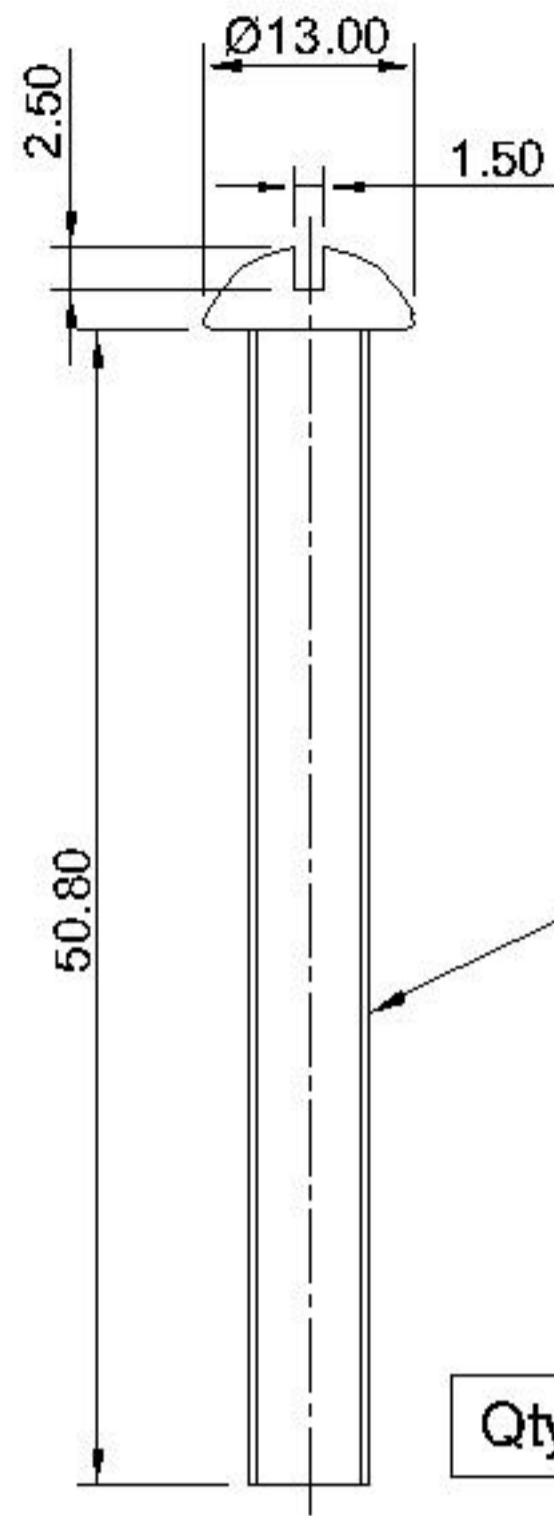

Qty:-2 Pcs.

5/16" x 18 BSW Thread

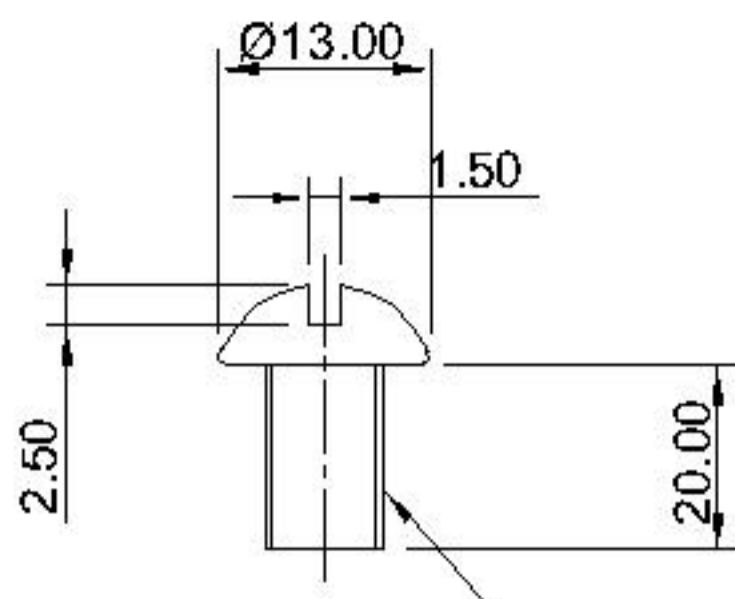

Qty:-1 Pcs.

5/16" x 18 BSW Thread

Screw and Pressure Plate for Adaptor

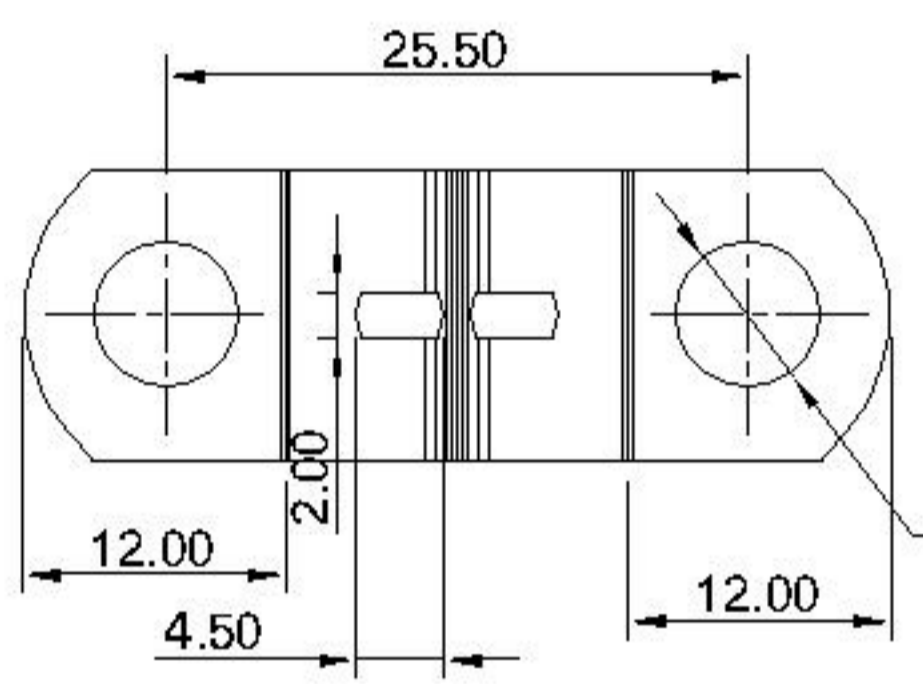

Ø6.50 x 2 Holes

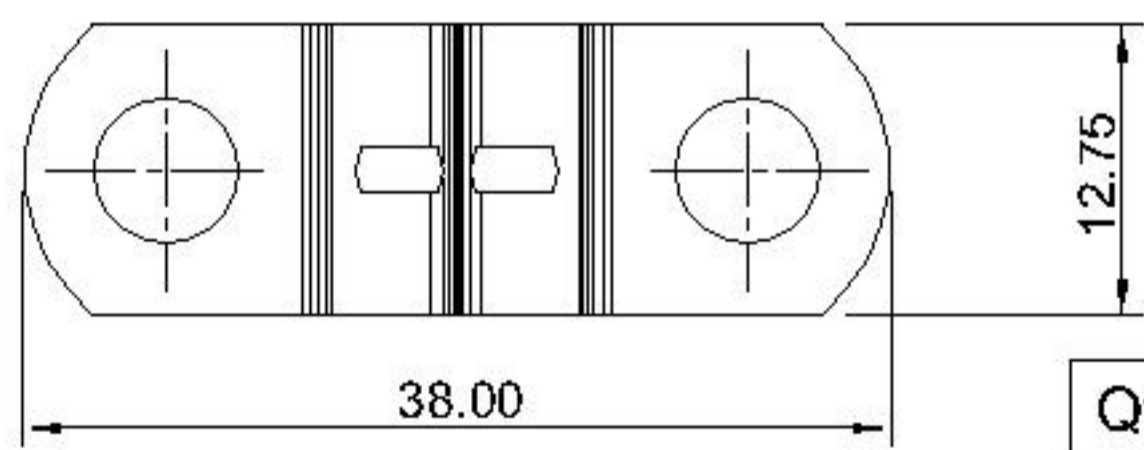
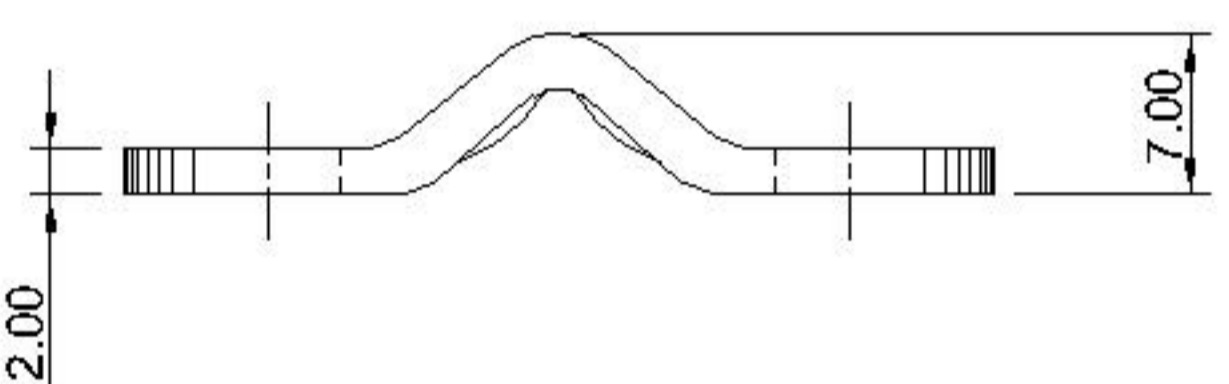

Qty:-2 Pcs.

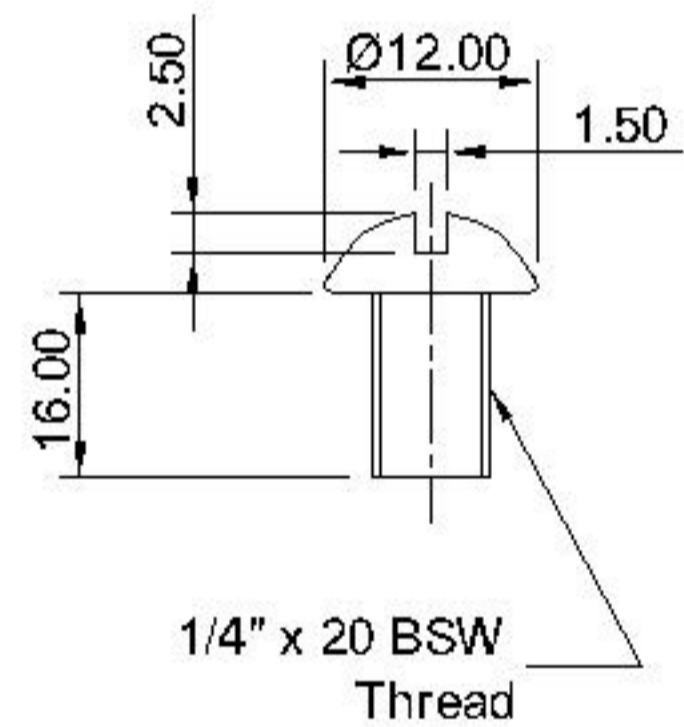

Qty:-4 Pcs.

1/4" x 20 BSW Thread



Morris Products Inc.

53 Carey Rd. Queensbury NY 12804

	NAME	DATE
DRAWN	N.D.Parmar	18/01/2004
CHECKED	V.G.Patel	18/01/2004
APPROVED	V.G.Patel	18/01/2004
MATERIAL-	Screws: M.S. Plates: Copper Alloy with copper above 80 %	
TOLERANCE-	±0.50	

SCALE- N.T.S. TITEL- Pressure Pads & Screws

TREATMENT-Screw-Blue Zinc Plated, Plates-Neutral All Dimensions are in mm

Drawing No.- 91692-D

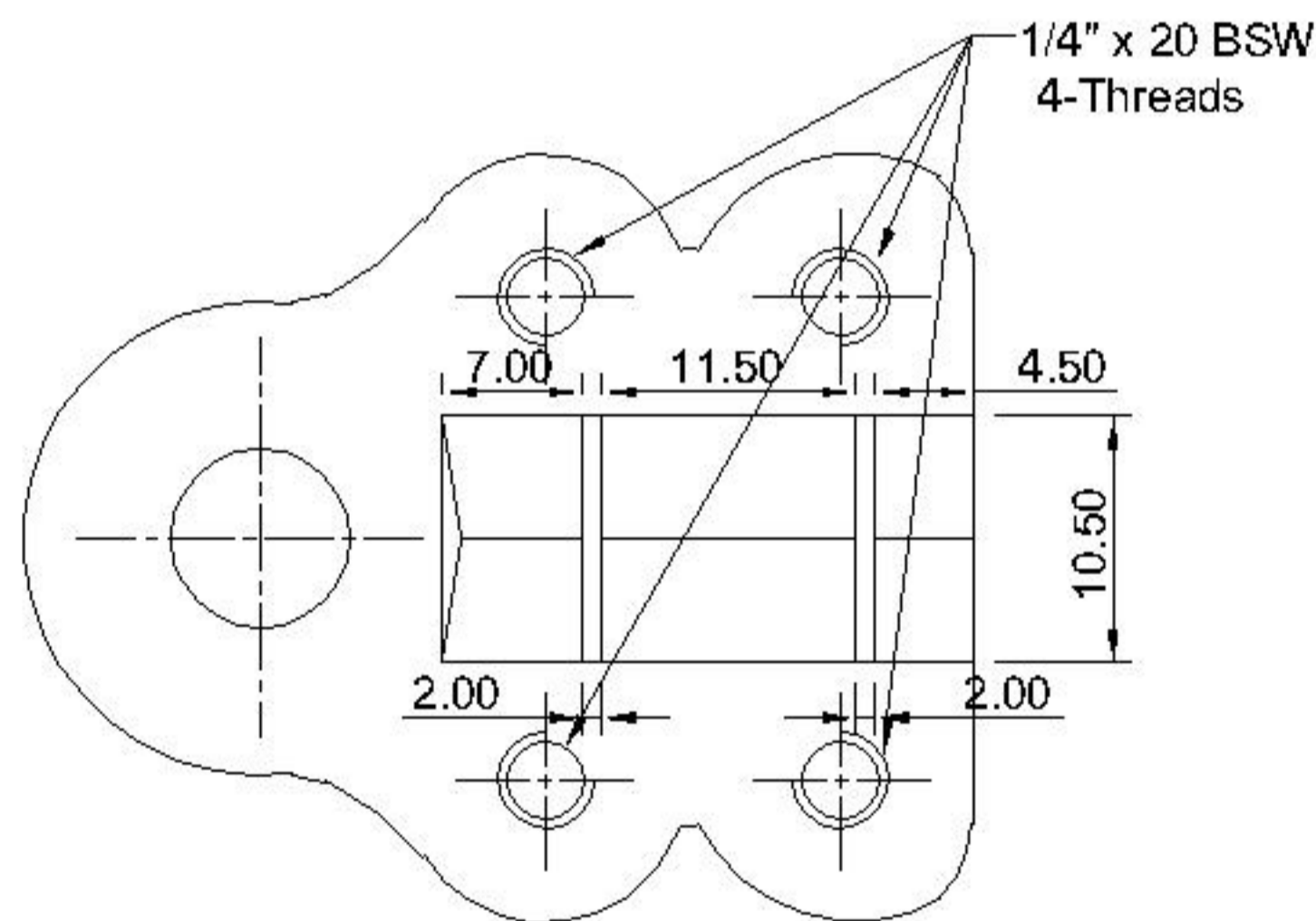
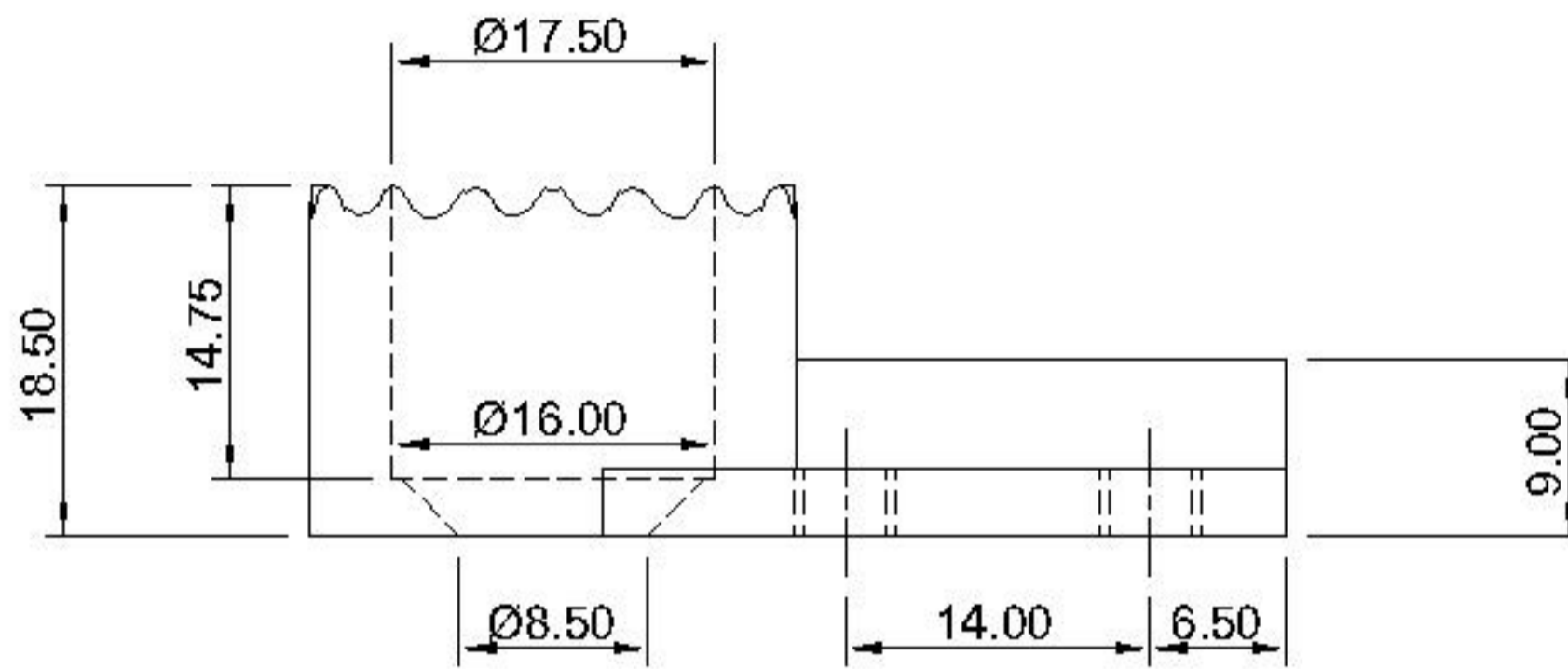
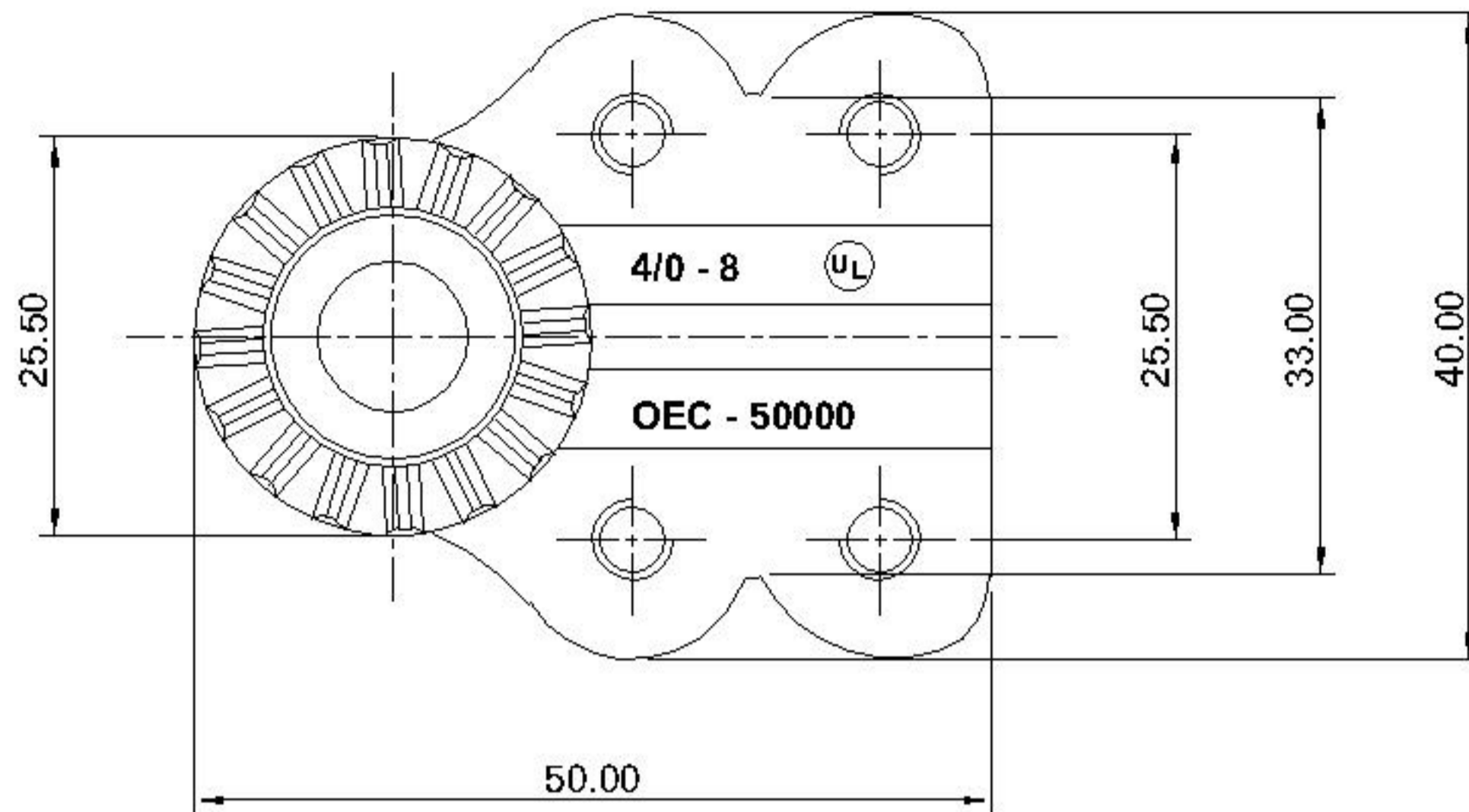

1/4" x 20 BSW
4-Threads



Morris Products Inc.

53 Carey Rd. Queensbury NY 12804

	NAME	DATE
DRAWN	N.D.Parmar	18/01/2004
CHECKED	V.G.Patel	18/01/2004
APPROVED	V.G.Patel	18/01/2004
MATERIAL-	Copper Alloy with copper above 80 %	
TOLERANCE-	± 0.50	

SCALE- N.T.S.

TITEL- **Adaptor**

TREATMENT- **Shot Blasting**

All Dimensions are in mm

Drawing No.- 91692-C