



**Catalog Number** 91690  
**UPC Number** 60198691690  
**Description** Copper Pipe Ground Clamp 1/2" - 1"  
with armored/unarmored cable adaptor  
Adaptor Serrations



#### Features

- Manufactured from High Strength High Conductivity Cast Copper Alloy
- Steel Zinc Plated Set Screws
- Water Pipe, Ground Rod, Copper Tubing applications
- Internal Serrations for improved contact integrity
- Serrated Apaptor for armored or unarmored cable ground

#### General

**Pipe Size:** 1/2" - 1"  
**Material:** High Conductivity Cast Copper  
**Screw Type:** Zinc coated steel  
**Screw Thread:**  
**Wire Range:** #8 awg - 4/0

#### Dimension Information

**Width:** 2.32"  
**Height:** 1.41"

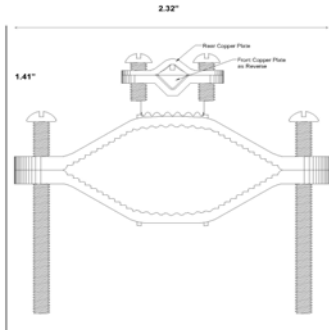

#### Specifications

**Temperature Rating**  
**Voltage Rating** 600  
**Flammability Rating**  
**Amp Rating**

#### Packaging

**Box Qty** 10

#### Certifications

**UL** Yes  
**cUL** Yes  
**RoHS** Yes

[www.morrisproducts.com](http://www.morrisproducts.com)

Morris Products 53 Carey Road, Queensbury, NY 12804

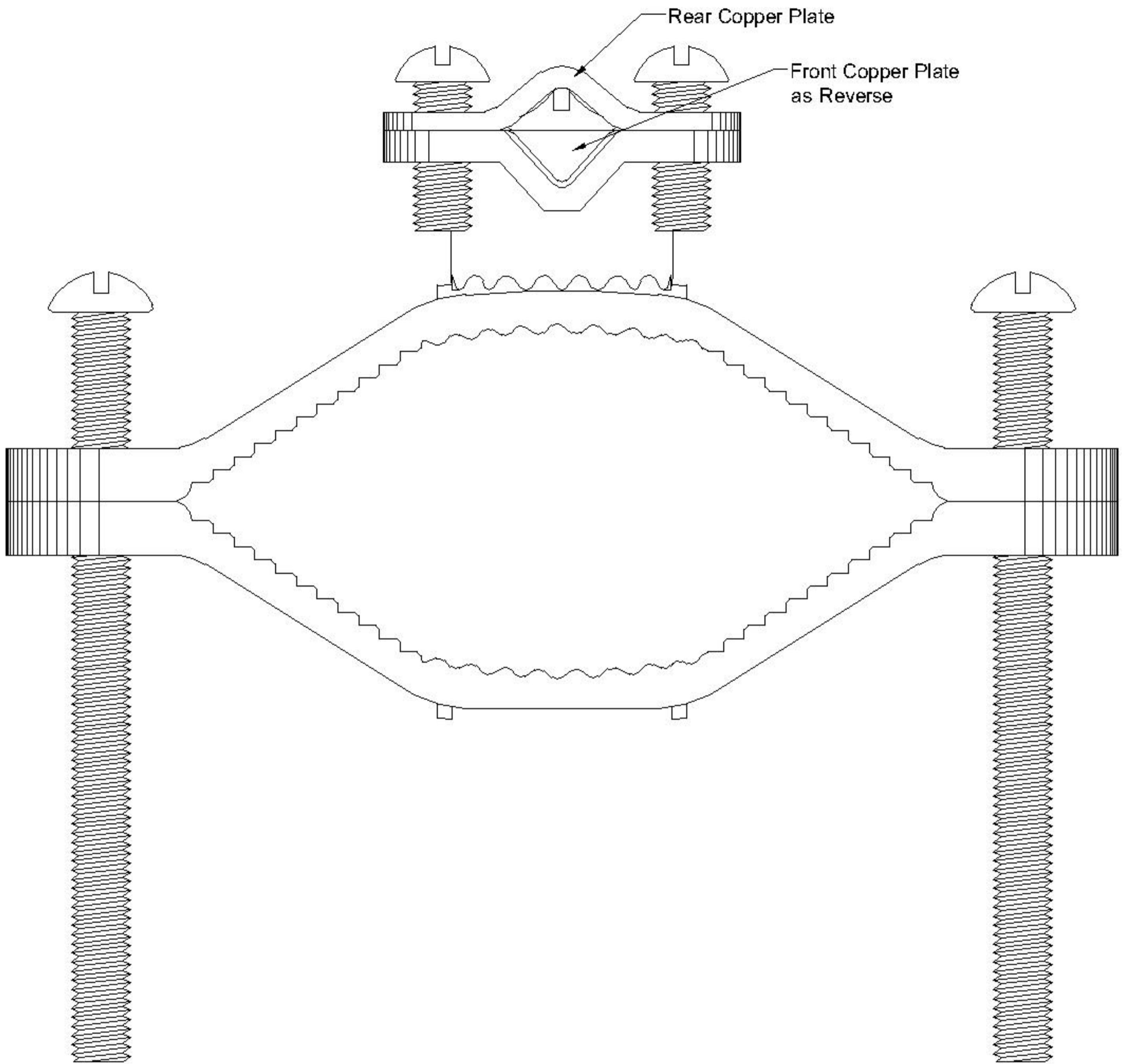

Morris Products Inc.

53 Carey Rd. Queensbury NY 12804

	NAME	DATE
DRAWN	C.Makwana	30/08/2006
CHECKED	Vivek	30/08/2006
APPROVED	V.G.Patel	30/08/2006
MATERIAL-	-----	
TOLERANCE-	-----	

TITEL - *Ground Clamp* - 1 (4/0-8)

SCALE- N.T.S. TREATMENT- -----

All Dimensions are in mm

Drawing No.- 91690

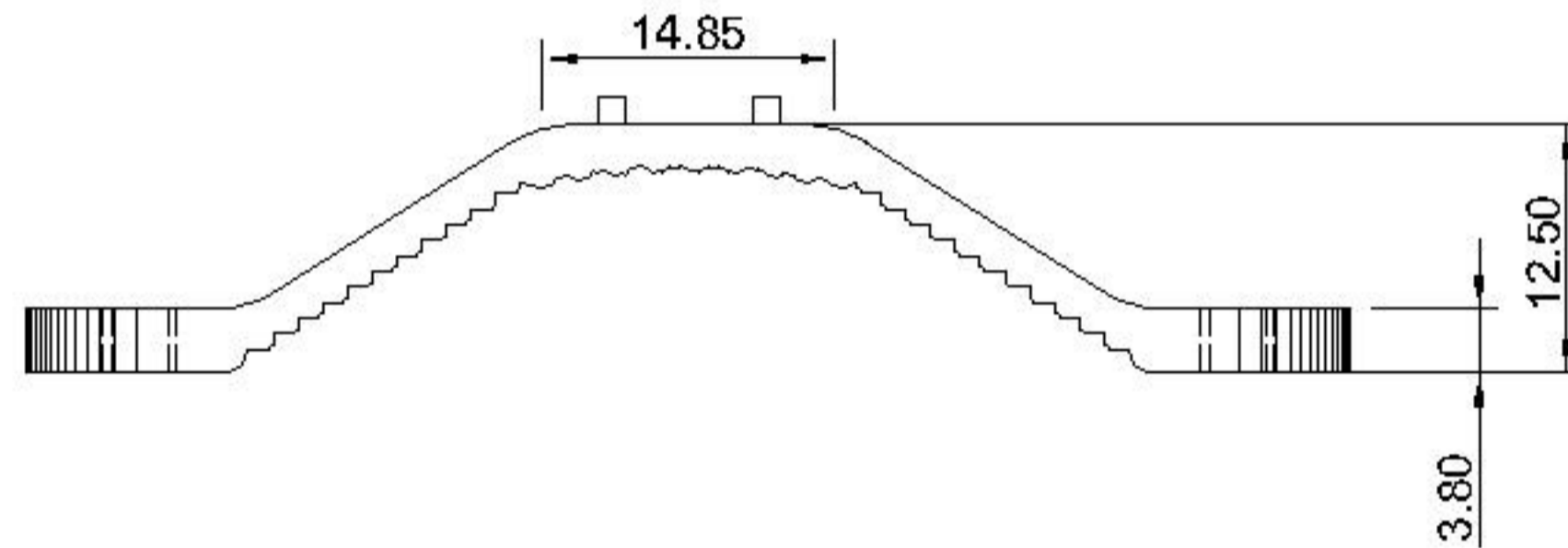
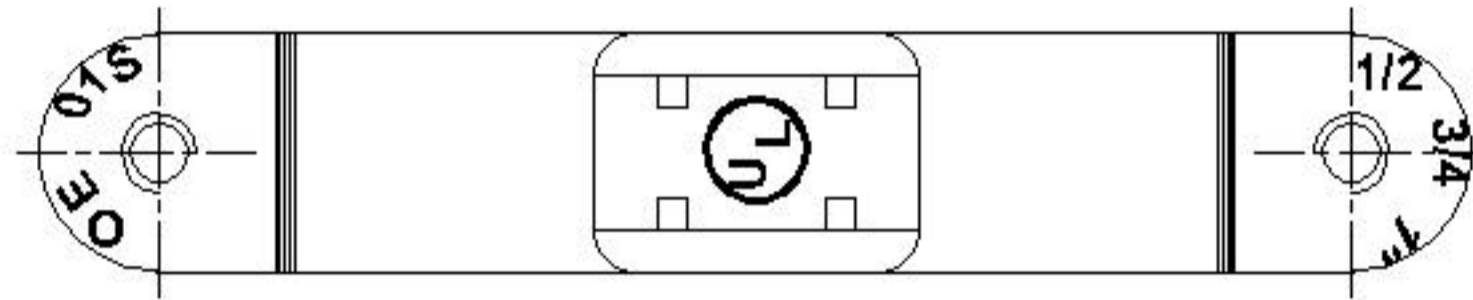
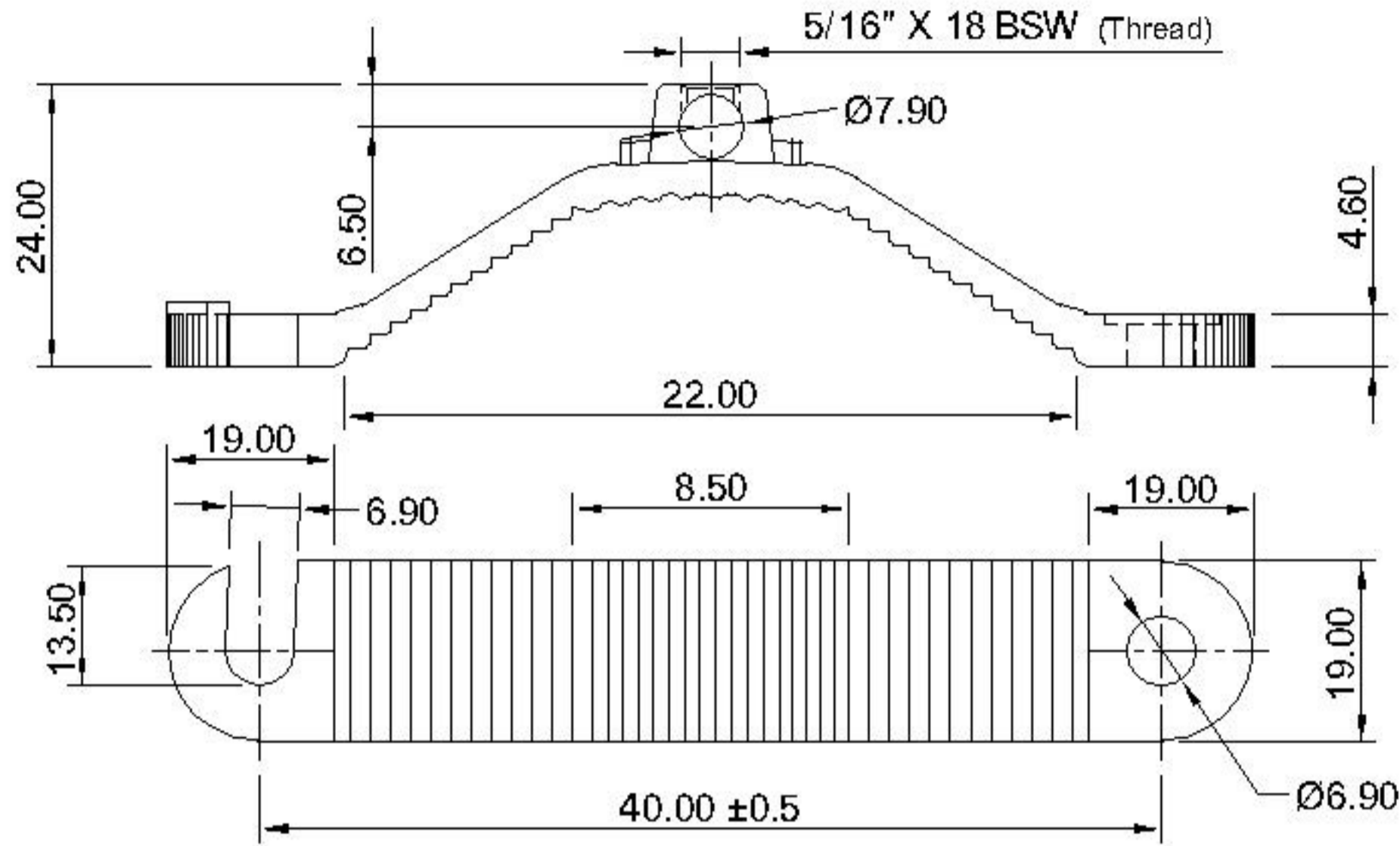
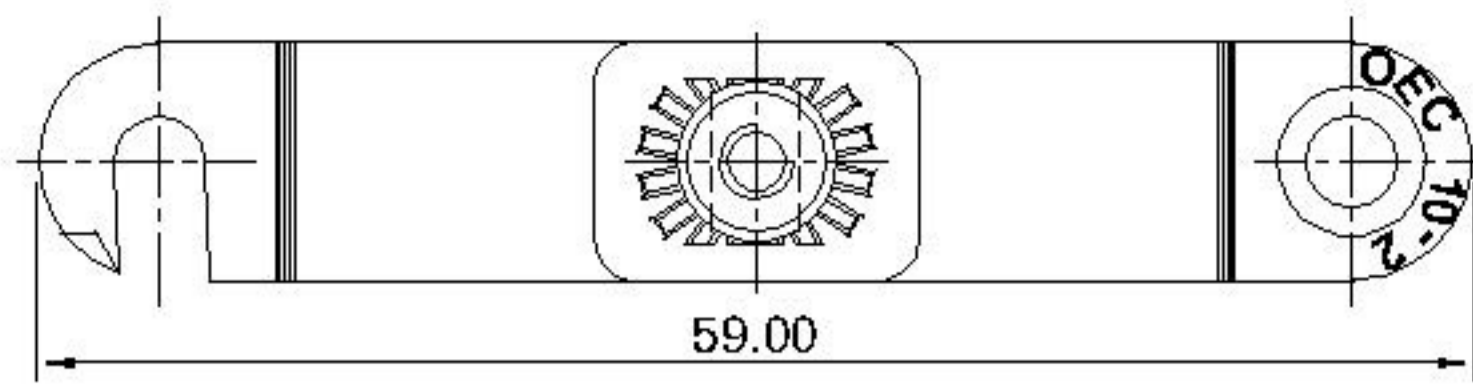

1/4" x 20 BSW  
Thread

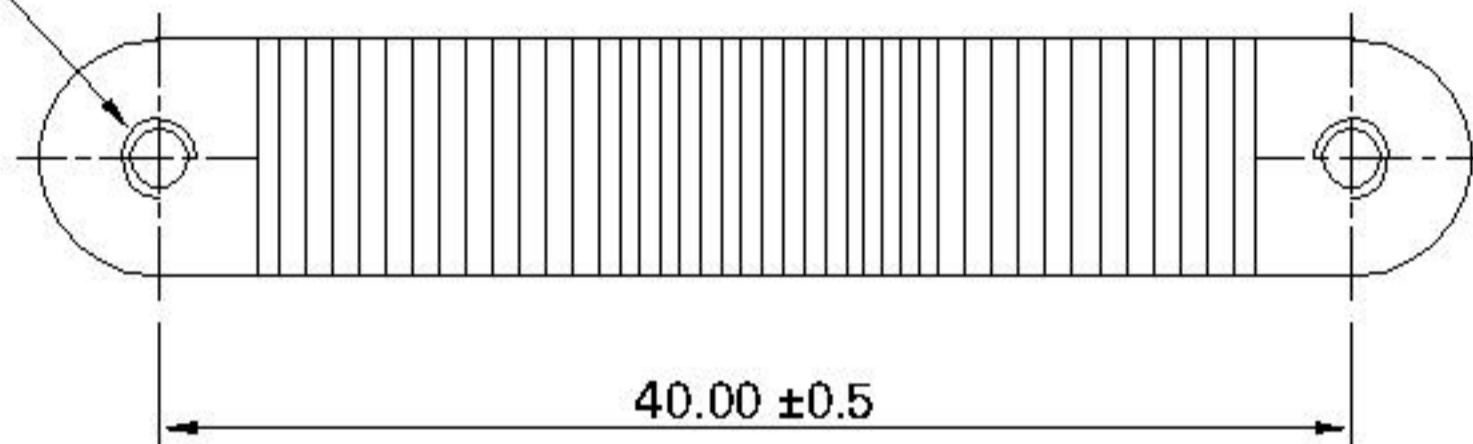

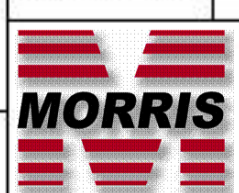
	NAME	DATE					
DRAWN	C.Makwana	30/08/2006					
CHECKED	Vivek	30/08/2006					
APPROVED	V.G. patel	30/08/2006	A	As Per Dimension Revises	17/05/2010	Parmar	V.G. patel
MATERIAL -	Copper Alloy with copper above 80 %		Rev. No.	Details of Revision	Date	Drawn	Approved
TREATMENT -	<i>Short Blasting</i>						
TOLERANCE -	±0.50		TITLE - <i>Ground Clamp</i> - 91690				
SCALE -	N.T.S.						
All dimensions are in mm.			Drawing No.- 91690-B			Weight :-	Size :- A4

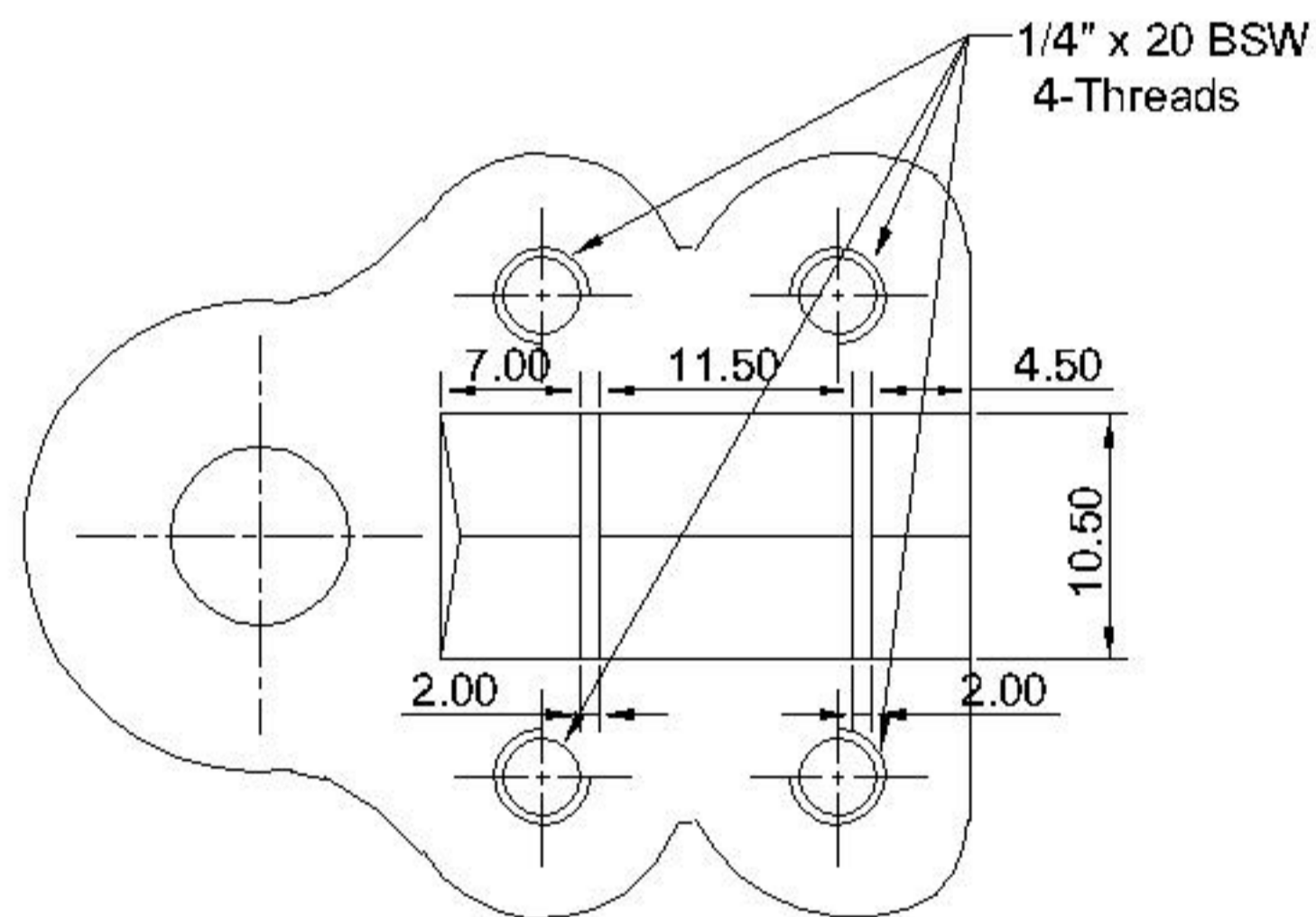
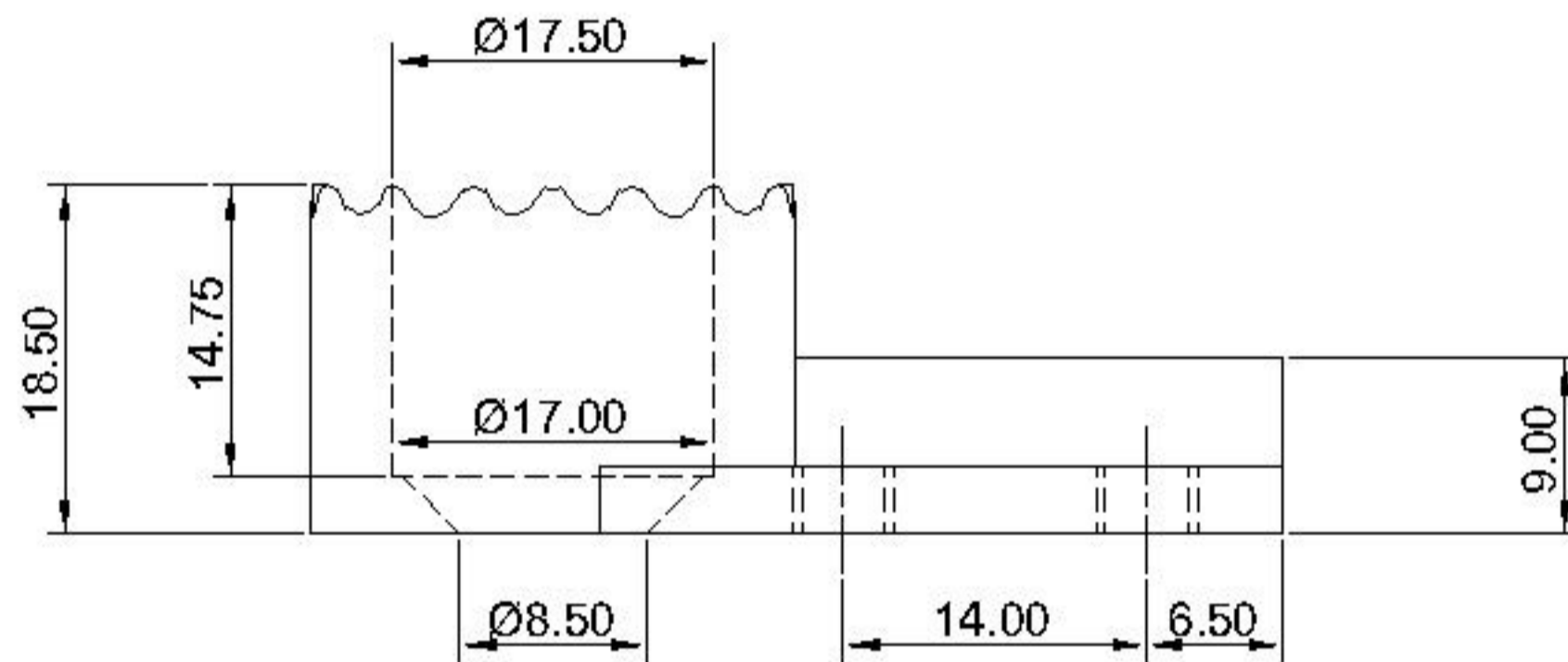
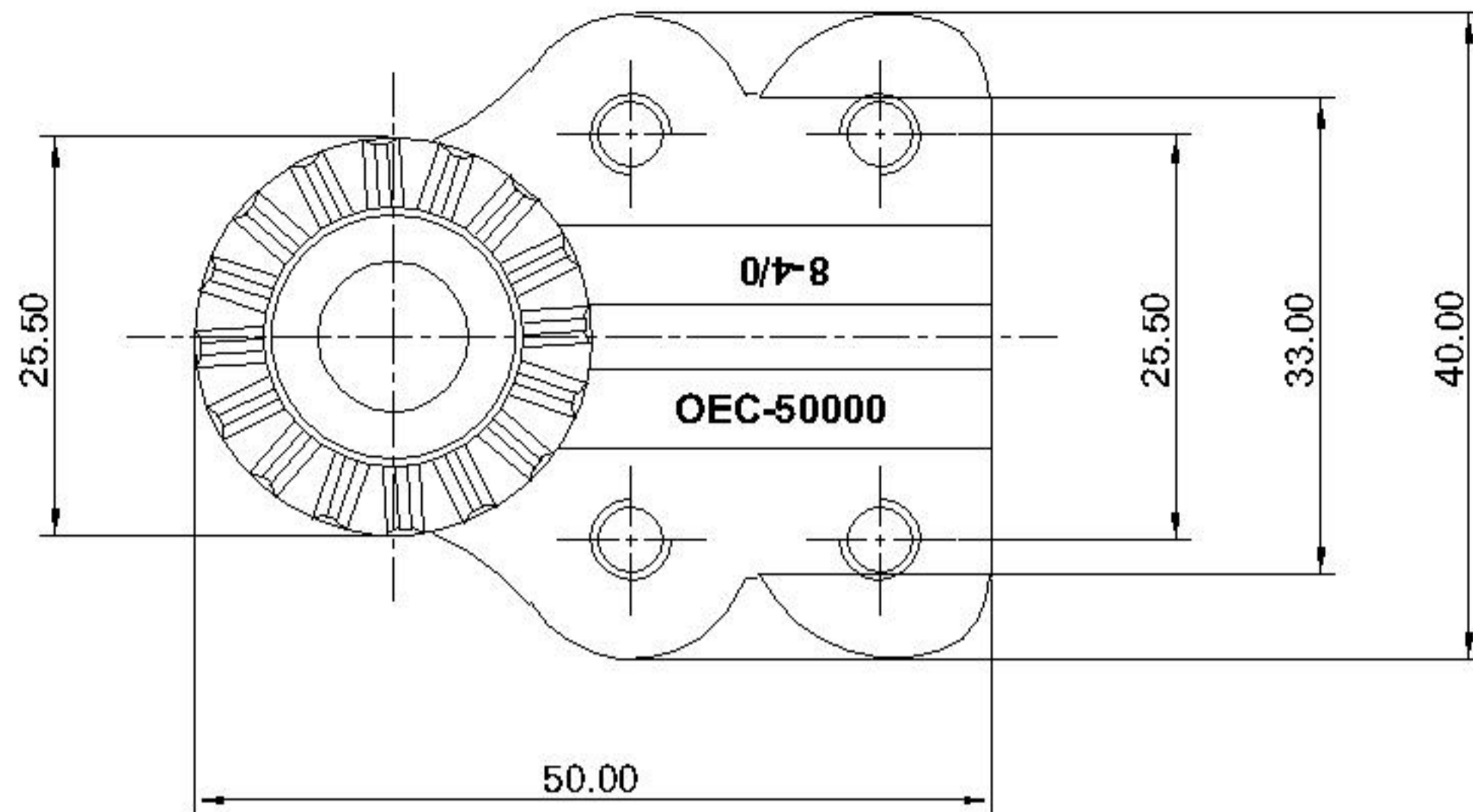

	NAME	DATE
DRAWN	C.Makwana	29/08/2006
CHECKED	Vivek	29/08/2006
APPROVED	V.G.Patel	29/08/2006
MATERIAL-	Copper Alloy with copper above 80 %	
TOLERANCE-	±0.50	

Adaptor - 91690

SCALE- N.T.S. TREATMENT- Shot Blasting

All Dimensions are in mm

Drawing No.- 91690-C

### Screws for Pipe Clamp

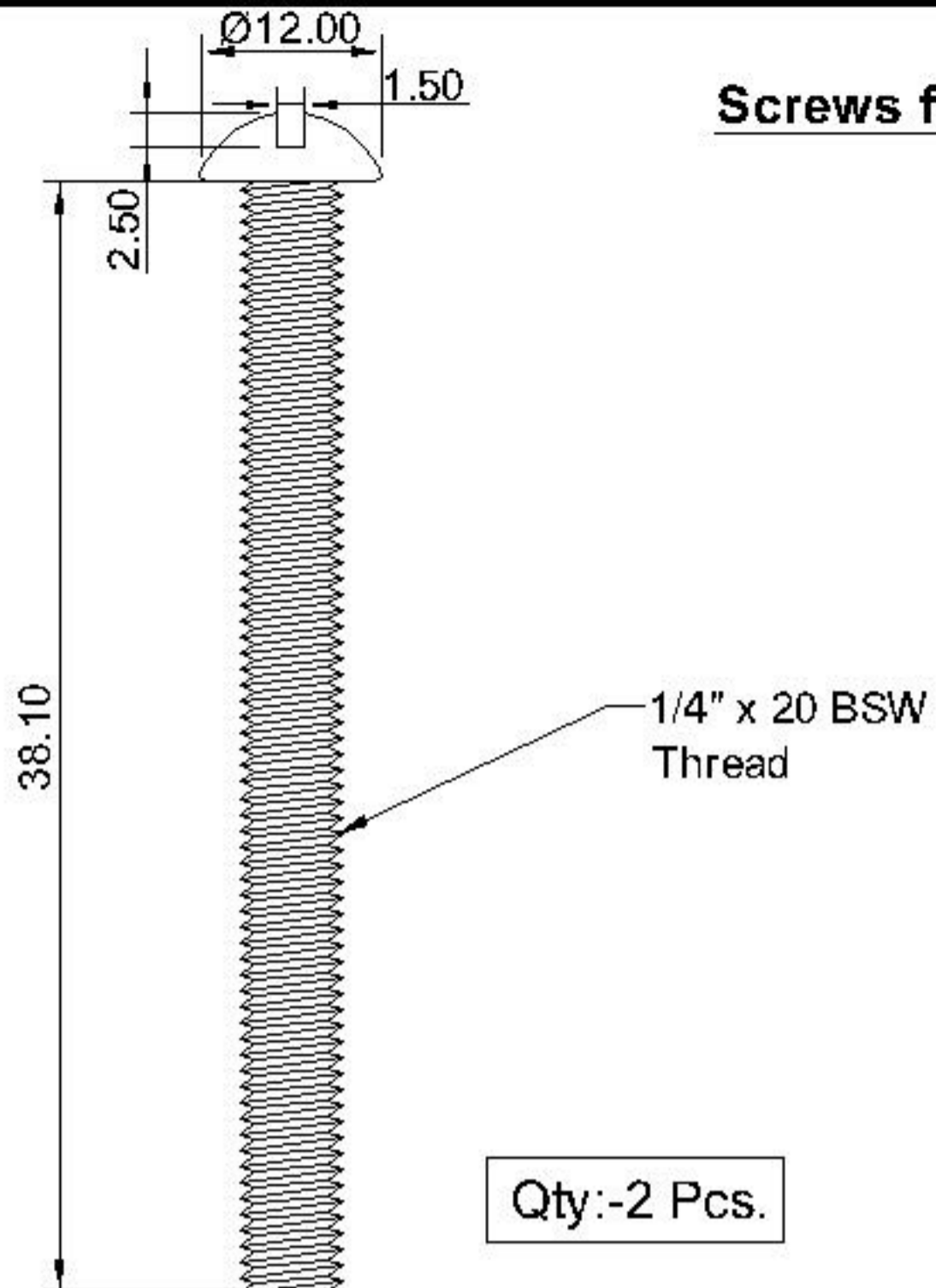

Qty:-2 Pcs.

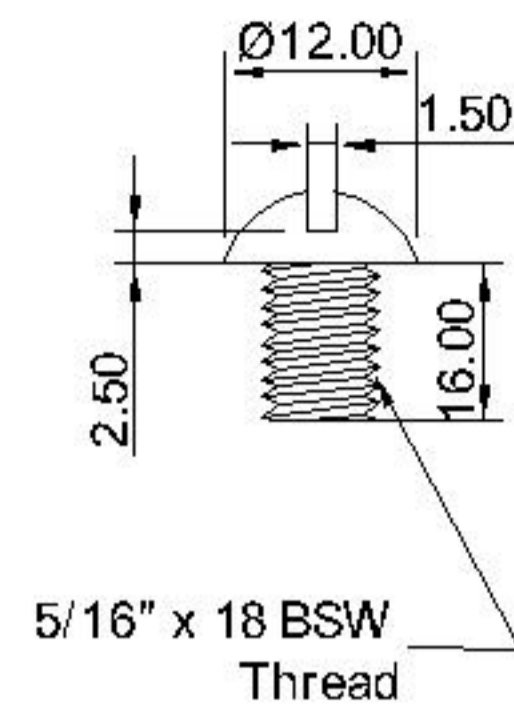

Qty:-1 Pcs.

### Screw and Pressure Plate for Adaptor

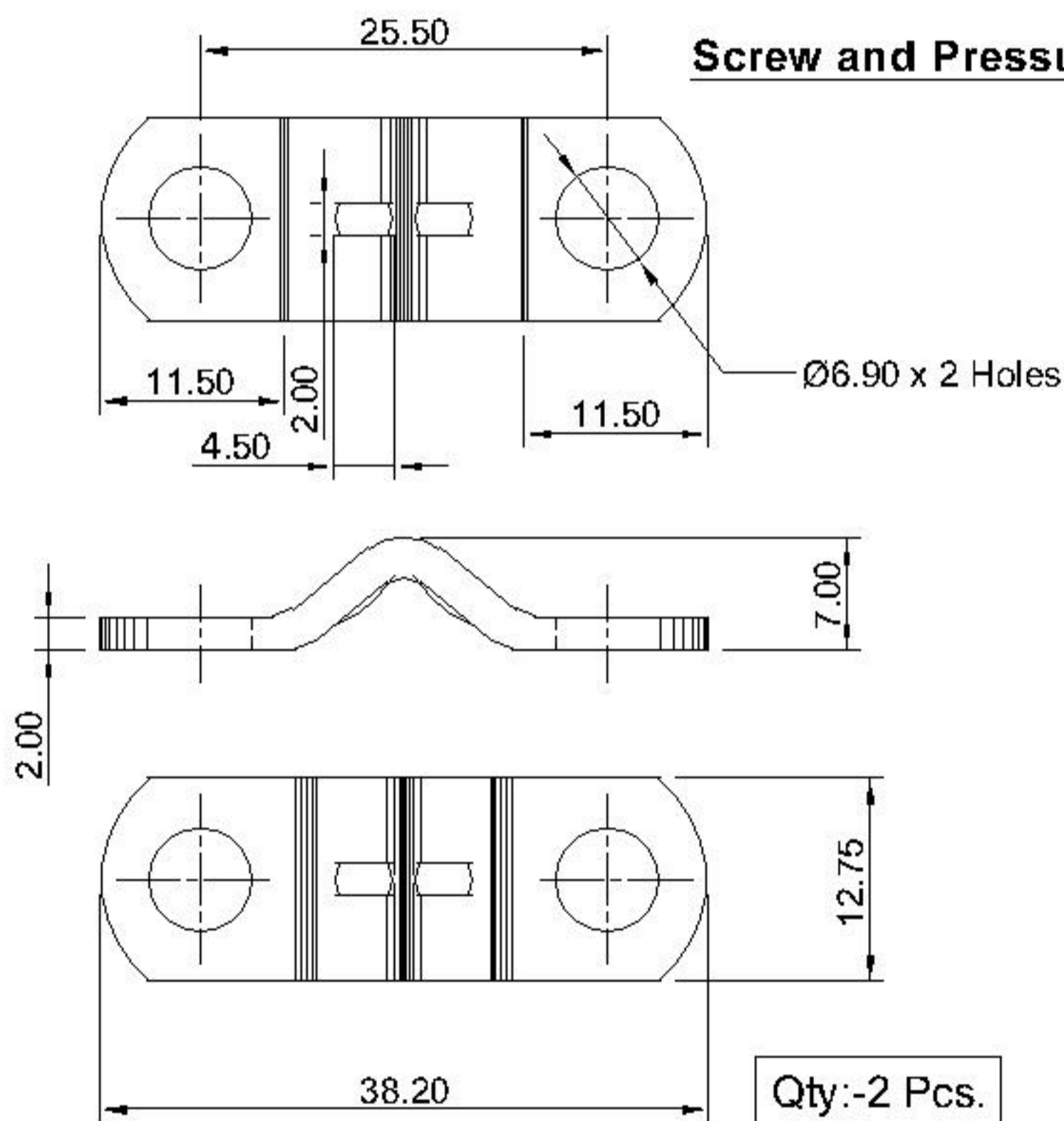

Qty:-2 Pcs.

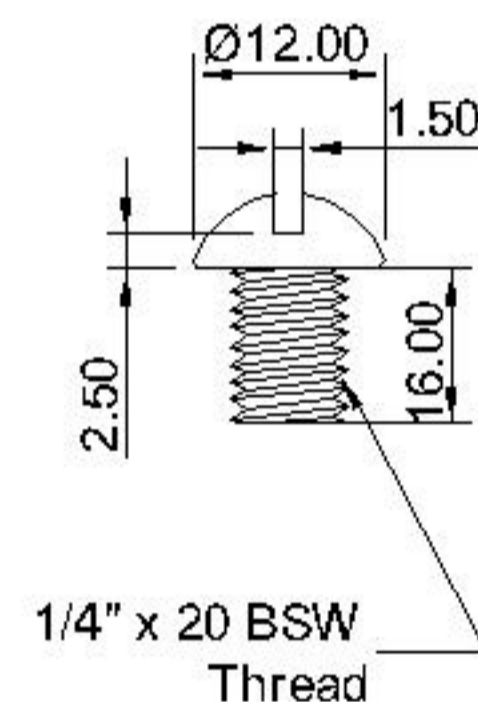

Qty:-4 Pcs.

	NAME	DATE						
DRAWN	C.Makwana	30/08/2006						
CHECKED	Vivak	30/08/2006						
APPROVED	V.G. Patel	30/08/2006	A	As Per Dimension Revoices	17/05/2010	Parmar	V.G. Patel	
MATERIAL - <b>Screws: M.S.</b> <b>Pad: Copper Alloy with copper above 80 %</b>			Rev. No.	Details of Revision	Date	Drawn	Approved	
TREATMENT - <b>Screw-Blue Zink Pad,</b> <b>Plates-Neutral</b>								
TOLERANCE - ±0.50			TITLE - <b>Pressure Pades &amp; Screws</b> 91690					
SCALE - N.T.S.								
All dimensions are in mm.			Drawing No.- 91690-D			Weight :-		Size :- A4