



**Catalog Number** 11754  
**UPC Number** 60198611754  
**Description** Non-Insulated Flanged Fork Spade Terminals  
 16-14 AWG



**Features**

Manufactured from high strength copper alloy  
 Electro-tin plated for corrosion resistance  
 Wire range stamped on the surface for easy interpretation  
 Brazed seam prevents splitting under maximum pressure  
 Serrated barrel provides excellent electrical contact and pull-out resistance characteristics at barrel  
 Flanged tabs on Tang for increased pull-out force resistance

**General**

**Insulation Type** N/A  
**Material** Copper  
**Finish** Electro-tin plated  
**Color** N/A  
**Wire Range** 16-14 AWG  
**Stud Size** #10

**Dimension Information**

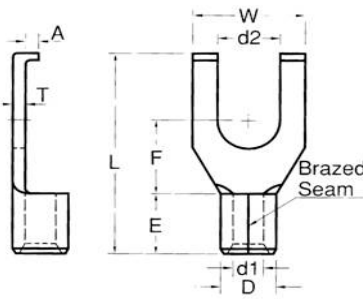

**L Inches (mm)** 0.709  
**W Inches (mm)** 0.335  
**D Inches (mm)** 0.161  
**d1 Inches (mm)** 0.091  
**d2 Inches (mm)** 0.209  
**E Inches (mm)** 0.189  
**F Inches (mm)** 0.283  
**A Inches (mm)** 0.059  
**T Inches (mm)** 0.031

**Specifications**

**Temperature Rating** 150°C  
**Voltage Rating** 600 V  
**Flammability Rating** N/A  
**Amp Rating** 16 AWG 18 Amps  
 14 AWG 30 Amps

**Packaging**

**Bag Qty** 100  
**Master Bag Qty** 1000

**Certifications**

**UL** Yes  
**cUL** Yes  
**RoHS** Yes

Morris Products 53 Carey Road, Queensbury, NY 12804

[www.morrisproducts.com](http://www.morrisproducts.com)



REV	DESCRIPTION	DATE
△	RDK-96036	2007/06/07
△	RDK-97127	2008/07/25
△	RDK-98020 AND UNIFIED TOLERANCE	2009/06/02

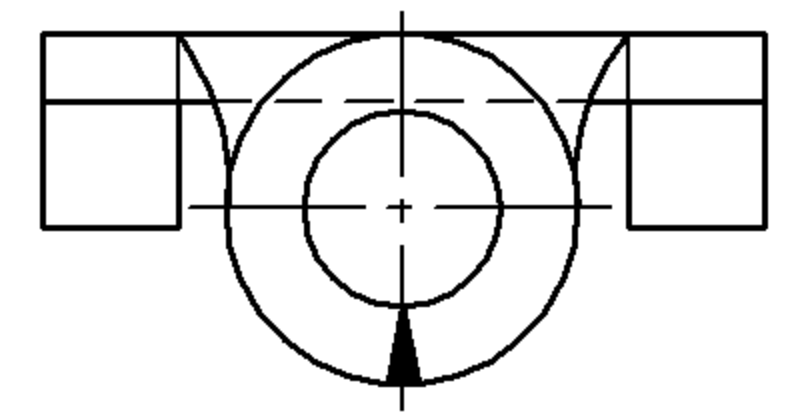
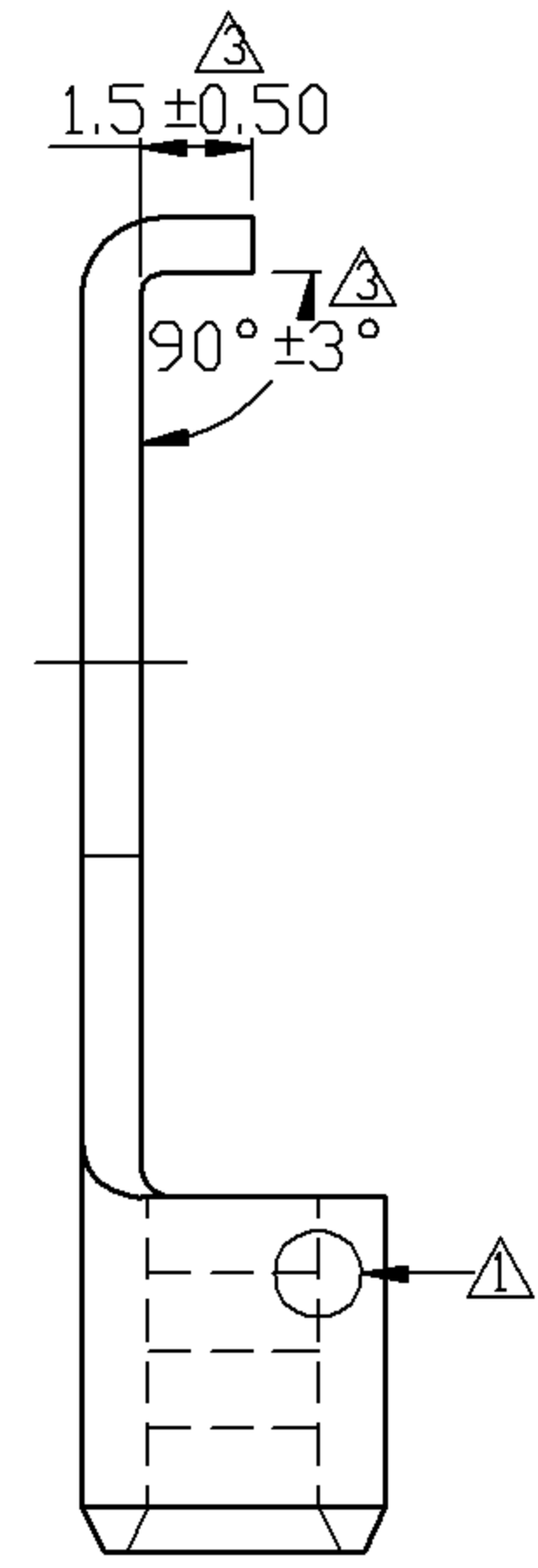
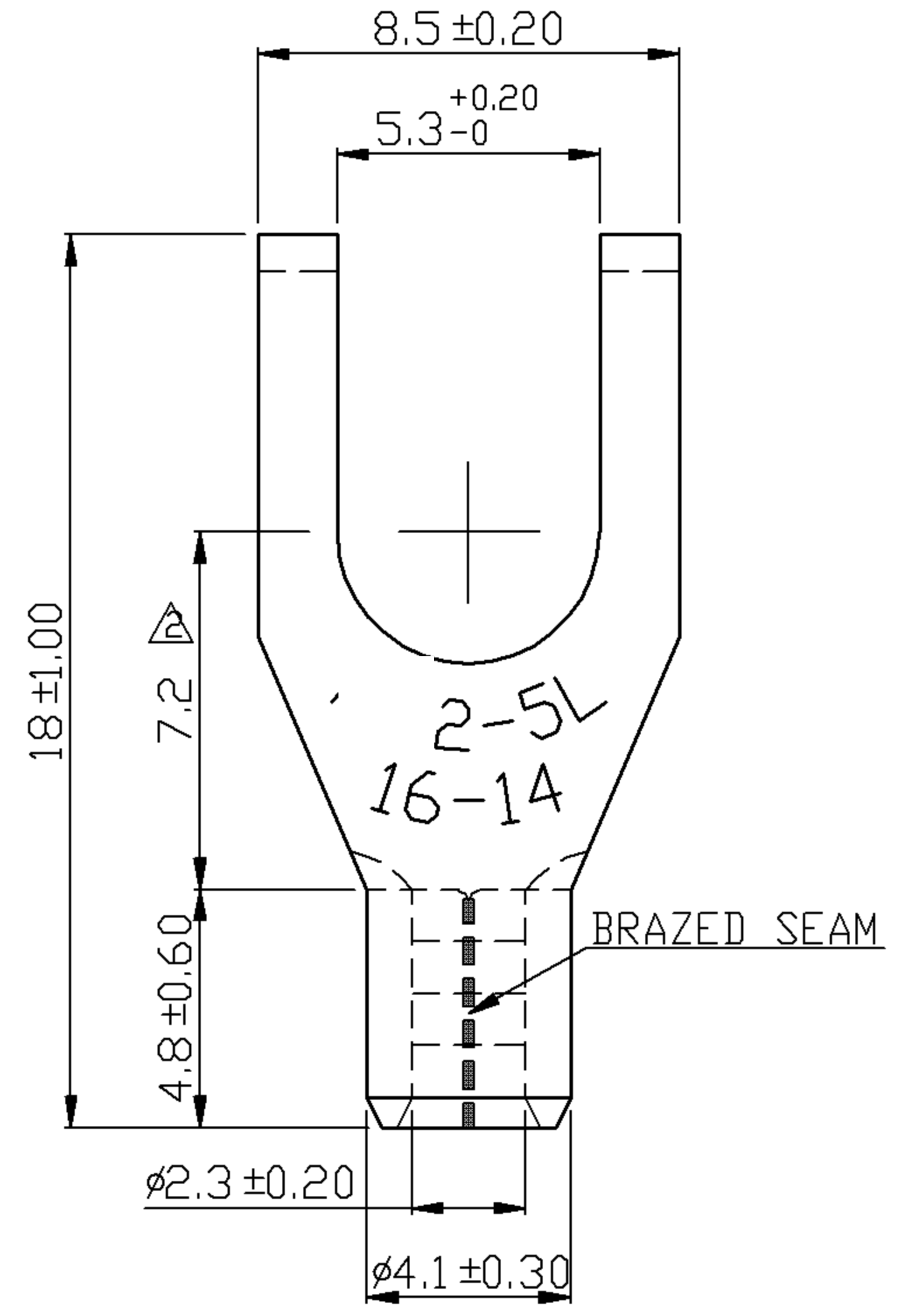

NOTE :

- MAXIMUM ELECTRIC CURRENT : 

A.W.G.	16	14	
AMP.	18	30	
- WIRE RANGE : 16-14 A.W.G. ( 1.5-2.5 mm<sup>2</sup> )
- SURFACE TREATMENT : TIN PLATED
- THICKNESS : 0.8 mm

△ Tolerance Unless	
□ Otherwise Specified	
0 >	mm ± ANGLE
>	mm ± 0° > ° REF ±
>	mm ± ° > ° ±
>	mm ± ° > ° ±

NAME	NON-INSULATED FLANGE SPADE TERMINALS			UNIT	
PART NO.	11754	MATERIAL	COPPER	APPROVE	
NUMBER		SCALE	SHEET PAGE	CHECKED	
DATE	2006/05/02	4/1	1-3 10F2	DRAWN	

Morris Products Inc.  
53 Carey Rd. Queensbury, NY 12804